

A-A ( 1.5 : 1 )

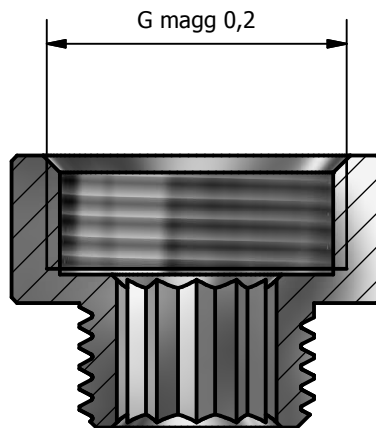

FILETTATURA ZIGRINATA

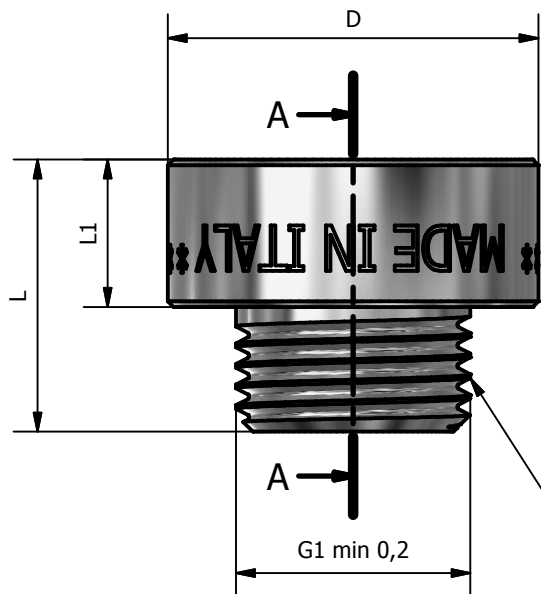
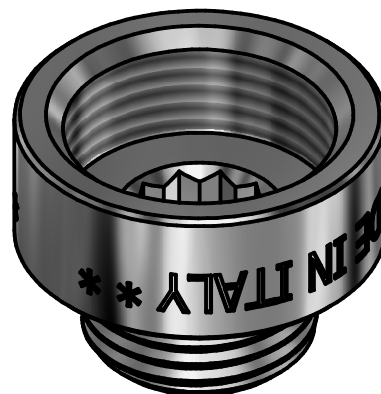
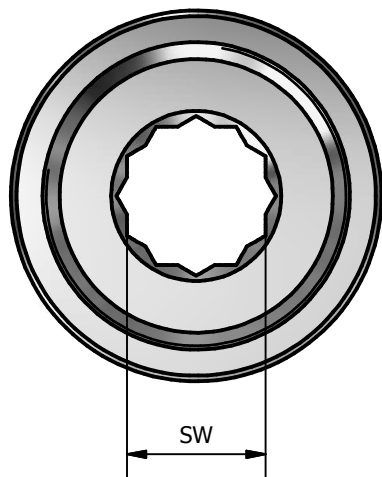

CODE	SIZE	G	G1	L	L1	D	SW
111C 1238	1/2x3/8	1/2	3/8	22,5	13	27	10,3
111C 3412	3/4x1/2	3/4	1/2	24	13	33	12,2
111C 0134	1"x3/4	1"	3/4	27	15	37,5	17,2

WORKING PRESSURE MAX	16 BAR
WORKING TEMPERATURE MAX	120°C

CONFORMITY
1) DM 174 del 6 Aprile 2004
2) UNI EN ISO 228
3) UNI EN 1254-4
4) UNI EN 9227
5) UNI EN 2819

00	Prima emissione	Delaini M.	08/02/2008
Rev.	Nota Revisione	Approvatore	Data Approvazione
Toll Gen:	JS14	Stato sup.:	Cromato
Filetto:	ISO 228	Note tecniche:	
Peso lavorato:	Peso grezzo:	N° stampo:	
Materiale: CW 617N EN12165		Disegnatore: Delaini P.	Data: 08/02/2008
TDM Brass s.r.l via Artigiani, 7-9 25030 Maclodio BS Italy tel +39 030 9972217 fax 030 9787089 www.tdmbrass.it email info@tdmbrass.it			

Codice: 111C scheda

Descrizione: Bush reducing